

# eurolite® **LED LASER DERBY**

Showlaser Light Effect

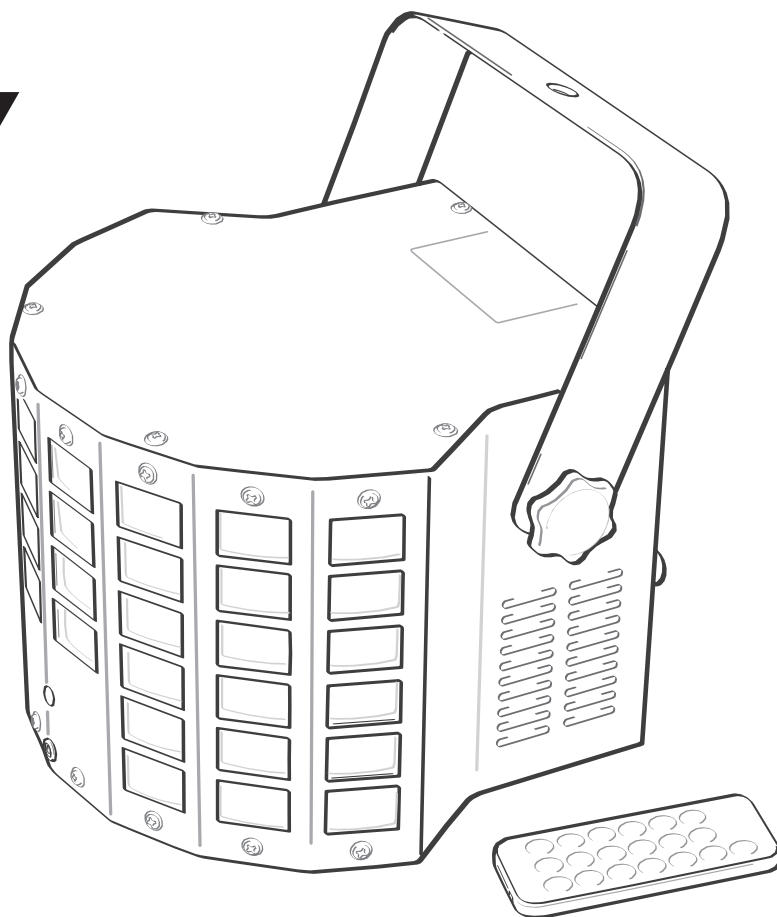

Bedienungsanleitung  
User Manual

**eurolite®**

## **LED Laser Derby**

Showlaser-Lichteffekt, Laserklasse 2M  
Showlaser light effect, laser class 2M



**No. 51741086**

[www.eurolite.de](http://www.eurolite.de)

# CONTENTS

<b>INTRODUCTION</b> .....	<b>16</b>
Product features .....	16
<b>IMPORTANT SAFETY INSTRUCTIONS</b> .....	<b>17</b>
<b>IMPORTANT INFORMATION FOR LASER PRODUCTS</b>	<b>18</b>
<b>PROTECTING THE ENVIRONMENT</b> .....	<b>18</b>
<b>OPERATING DETERMINATIONS</b> .....	<b>19</b>
<b>OPERATING ELEMENTS AND CONNECTIONS</b> .	<b>20</b>
Front panel.....	20
Rear panel.....	20
<b>INSTALLATION</b> .....	<b>21</b>
<b>MAKING THE CONNECTIONS</b> .....	<b>22</b>
Connection to the mains.....	22
DMX512 control .....	22
<b>MENU SETTINGS</b> .....	<b>23</b>
Operating buttons.....	23
Menu structure.....	23
<b>OPERATION WITHOUT EXTERNAL CONTROL</b> .	<b>23</b>
Automatic mode .....	23
Sound control .....	23
Interconnecting several showlasers (master/slave operation) .	24
<b>REMOTE CONTROL</b> .....	<b>24</b>
<b>DMX OPERATION</b> .....	<b>25</b>
Setting the number of DMX channels and the DMX starting address .....	25
Functions in DMX mode .....	25
<b>CLEANING AND MAINTENANCE</b> .....	<b>26</b>
Replacing the fuse .....	26
<b>TECHNICAL SPECIFICATIONS</b> .....	<b>26</b>
Accessories.....	26

D00110324, version 1.1, publ. 08/02/2018

For product updates, documentation, software and support please visit [www.eurolite.de](http://www.eurolite.de). You can find the latest version of this user manual in the product's download section.

© 2018 Eurolite. All rights reserved.

No part of this document may be reproduced in any form without the written permission of the copyright owner. The contents of this document are subject to revision without notice due to continued progress in methodology, design, and manufacturing. Eurolite shall have no liability for any error or damage of any kind resulting from the use of this document.

All trademarks mentioned herein are the property of their respective owners.

# INTRODUCTION

## Experience Eurolite.

Product videos, suitable accessories, firmware and software updates, documentation and the latest news about the brand. You will find this and much more on our website. You are also welcome to visit our YouTube channel and find us on Facebook.



[www.eurolite.de](http://www.eurolite.de)



[www.youtube.com/eurolitevideo](http://www.youtube.com/eurolitevideo)



[www.facebook.com/Eurolitefans](http://www.facebook.com/Eurolitefans)

Welcome to Eurolite! Thank you for choosing one of our products. Eurolite is your connection to the world of show with an unparalleled variety of products, both for professionals and beginners.

If you follow the instructions given in this manual, we are sure that you will enjoy this product for a long period of time. This user manual will show you how to install, set up and operate your new Eurolite product.

Users of this product are recommended to carefully read all warnings in order to protect yourself and others from damage. Please keep this manual for future needs and pass it on to further owners.

## Product features

- DMX light effect with RG laser, rotating LED derby and IR remote control
- 1 bright 4in1 RGBW LED (30 W) for striking mirror ball effects
- 44 precision lenses fill the room with razor-sharp beams in RGBW colors
- 2 laser diodes project hundreds of red and green laser beams
- Auto, music, master/slave and DMX mode
- 4 built-in auto and music show programs
- Strobe effect, color change, color fade, direct color selection
- Convenient wireless control via included IR remote control
- Addressing and setting via control panel with 4-digit LED display
- Laser class 2M: does not require additional protective measures or appointment of a laser safety officer
- Sound-control via built-in microphone with sensitivity control
- Metal housing with movable mounting bracket

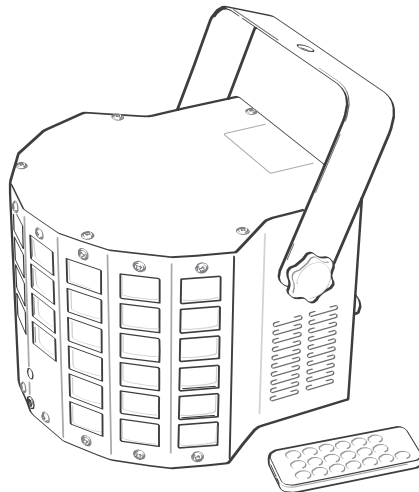

## IMPORTANT SAFETY INSTRUCTIONS

### CAUTION!



#### Operating conditions

This device has been designed for indoor use only. Keep this device away from rain and moisture.

### DANGER!



#### Electric shock caused by short-circuit

Be careful with your operations. With a dangerous voltage you can suffer a dangerous electric shock when touching the wires!

- This device has left our premises in absolutely perfect condition. In order to maintain this condition and to ensure a safe operation, it is absolutely necessary for the user to follow the safety instructions and warning notes written in this user manual.
- Damages caused by the disregard of this user manual are not subject to warranty. The dealer will not accept liability for any resulting defects or problems.
- Unpack and carefully check that there is no transportation damage before using the device. Should you notice any damages, do not take the device into operation and immediately consult your local dealer.
- Keep the packaging. To fully protect the device against vibration, dust and moisture during transportation or storage use the original packaging.
- This device falls under protection class I. The power plug must only be plugged into a protection class I outlet. The voltage and frequency must exactly be the same as stated on the device. Wrong voltages or power outlets can lead to the destruction of the device and to mortal electrical shock.
- Always plug in the power plug least. The power plug must always be inserted without force. Make sure that the plug is tightly connected with the outlet.
- Never let the power cord come into contact with other cables! Handle the power cord and all connections with the mains with particular caution! Never touch them with wet hands, as this could lead to mortal electrical shock.
- Never modify, bend, strain mechanically, put pressure on, pull or heat up the power cord. Never operate next to sources of heat or cold. Disregard can lead to power cord damages, fire or mortal electrical shock.
- The cable insert or the female part in the device must never be strained. There must always be sufficient cable to the device. Otherwise, the cable may be damaged which may lead to mortal damage.
- Make sure that the power cord is never crimped or damaged by sharp edges. Check the device and the power cord from time to time.
- If extension cords are used, make sure that the core diameter is sufficient for the required power consumption of the device. All warnings concerning the power cords are also valid for possible extension cords.
- Always disconnect from the mains, when the device is not in use or before cleaning it. Only handle the power cord by the plug. Never pull out the plug by tugging the power cord. Otherwise, the cable or plug can be damaged leading to mortal electrical shock. If the power plug or the power switch is not accessible, the device must be disconnected via the mains.
- If the power plug or the device is dusty, the device must be taken out of operation, disconnected and then be cleaned with a dry cloth. Dust can reduce the insulation which may lead to mortal electrical shock. More severe dirt in and at the device should only be removed by a specialist.
- There must never enter any liquid into power outlets, extension cords or any holes in the housing of the device. If you suppose that also a minimal amount of liquid may have entered the device, it must immediately be disconnected. This is also valid, if the device was exposed to high humidity. Also if the device is still running, the device must be checked by a specialist if the liquid has reduced any insulation. Reduced insulation can cause mortal electrical shock.
- There must never be any objects entering into the device. This is especially valid for metal parts. If any metal parts like staples or coarse metal chips enter into the device, the device must be taken out of operation and disconnected immediately. Malfunction or short-circuits caused by metal parts may cause mortal injuries.
- There are no serviceable parts inside the device. Maintenance and service operations are only to be carried out by authorized dealers!

## IMPORTANT INFORMATION FOR LASER PRODUCTS

### DANGER!



#### Damage caused by laser radiation

Avoid direct eye exposure. Never view directly with optical instruments (e.g. magnifying lens or telescope). Laser radiation can cause eye damage and/or skin damage. All protective measures for a safe operation of this laser must be applied.

#### Safety measures which must be observed

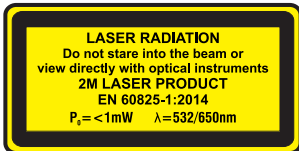

- This device includes a class 2M laser according to the EN 60825-1. The accessible laser radiation is exclusively within the visible spectral range (400 nm to 700 nm). However, a short-term exposure (max. 0.25 seconds) is not hazardous to the eye. A longer exposure is prevented by the natural eyelid closing reflex. Nevertheless, close your eyes or turn away immediately if the laser beam hits the eye. The corresponding warning is attached to the housing.
- The operator must comply with the country-specific accident prevention regulations of the government safety organization for electrical facilities.
- The corresponding accident prevention regulation of the accident prevention and insurance association in Germany is BGV-B2.
- This product must only be mounted, commissioned and operated by suitably qualified specialist personnel and only under observance of the requirements stated in the operating instructions.
- The use of operating and adjustment equipment and procedures other than those indicated here can lead to dangerous exposure to radiation.
- Do not stare into the laser beam and do not aim the laser at another person or animals. Laser radiation may result in injuries to the eyes or skin.
- Do not look into the laser beam with optical instruments (e.g. magnifying glasses or binoculars) under any circumstances. Laser radiation can cause eye damage and/or skin damage.
- Do not point the laser beam at mirrors or other reflective surfaces. The uncontrolled, reflected beam may strike people or animals.
- Always set up and install the unit so that a minimum distance of 1 m is kept between the laser light and the audience.
- Mark the area where this laser equipment is used by means of barriers and warning signs etc.
- Caution laser diode! Do not open or modify the unit. A modification can result in a more hazardous laser radiation which considerably deviates from the specified values.

## PROTECTING THE ENVIRONMENT

#### Disposal of old equipment



When to be definitively put out of operation, take the product to a local recycling plant for a disposal which is not harmful to the environment. Devices marked with this symbol must not be disposed of as household waste. Contact your retailer or local authorities for more information. Remove any inserted batteries and dispose of them separately from the product.



You as the end user are required by law (Battery Ordinance) to return all used batteries/rechargeable batteries. Disposing of them in the household waste is prohibited. You may return your used batteries free of charge to collection points in your municipality and anywhere where batteries/rechargeable batteries are sold. By disposing of used devices and batteries correctly, you contribute to the protection of the environment.

## OPERATING DETERMINATIONS

- The LED Laser Derby is a showlaser for generating laser and LED lighting effects. Control is possible directly at the unit, via DMX or via IR remote control.
- This device is designed for professional use in the field of event technology, e.g. on stage. It is not suitable as household lighting.
- The country-specific safety regulations and standards for laser operation must be complied with at all times.
- This device may be used only by persons with sufficient physical, sensorial, and intellectual abilities and having corresponding knowledge and experience. Other persons may use this device only if they are supervised or instructed by a person who is responsible for their safety.
- This product is only allowed to be operated with an alternating voltage of 100-240 V, 50/60 Hz and was designed for indoor use only. The occupation of the connection cables is as follows:

Cable	Pin	International
Brown	Live	L
Blue	Neutral	N
Yellow/Green	Earth	

The earth has to be connected! If the device will be directly connected with the local power supply network, a disconnection switch with a minimum opening of 3 mm at every pole has to be included in the permanent electrical installation. The device must only be connected with an electric installation carried out in compliance with the IEC standards. The electric installation must be equipped with a Residual Current Device (RCD) with a maximum fault current of 30 mA.

- Lighting effects are not designed for permanent operation. Consistent operation breaks will ensure that the device will serve you for a long time without defects.
- Do not shake the device. Avoid brute force when installing or operating the device. When choosing the installation spot, please make sure that the device is not exposed to extreme heat, moisture or dust. There should not be any cables lying around. You endanger your own and the safety of others!
- This device must never be operated or stockpiled in surroundings where splash water, rain, moisture or fog may harm the device. Moisture or very high humidity can reduce the insulation and lead to mortal electrical shocks. When using smoke machines, make sure that the device is never exposed to the direct smoke jet and is installed in a distance of 0.5 meters between smoke machine and device. The room must only be saturated with an amount of smoke that the visibility will always be more than 10 meters.
- This product was designed for indoor use only. The ambient temperature must always be between -5° C and +45° C.

- Keep away from direct insulation and heaters. The relative humidity must not exceed 50 % with an ambient temperature of 45° C.
- Do not expose this product to flammable materials.
- This device must only be operated in an altitude between -20 and 2000 m over NN.
- Never use the device during thunderstorms. Over voltage could destroy the device. Always disconnect the device during thunderstorms.
- Make sure that the installation complies with the standards and rules that apply in your country, in particular EN 60598-2-17. The device must be installed securely and prevented from falling down. Always secure it with an appropriate safety bond.
- Make sure that the area below the installation place is blocked when rigging, derigging or servicing the fixture.
- In order to safeguard sufficient ventilation, leave 50 cm of free space around the device. The housing must never touch surrounding surfaces or objects.
- Do not look directly at the light source! Persons with light-sensitive epilepsy may suffer from epileptic seizures or fall unconscious.
- Please consider that unauthorized modifications on the device are forbidden due to safety reasons!
- If this device will be operated in any way different to the one described in this manual, the product may suffer damages and the guarantee becomes void. Furthermore, any other operation may lead to dangers like injuries to the eyes, short-circuit, burns, electric shock, crash etc.
- Never remove the serial barcode from the device as this would make the guarantee void.

# OPERATING ELEMENTS AND CONNECTIONS

## Front panel

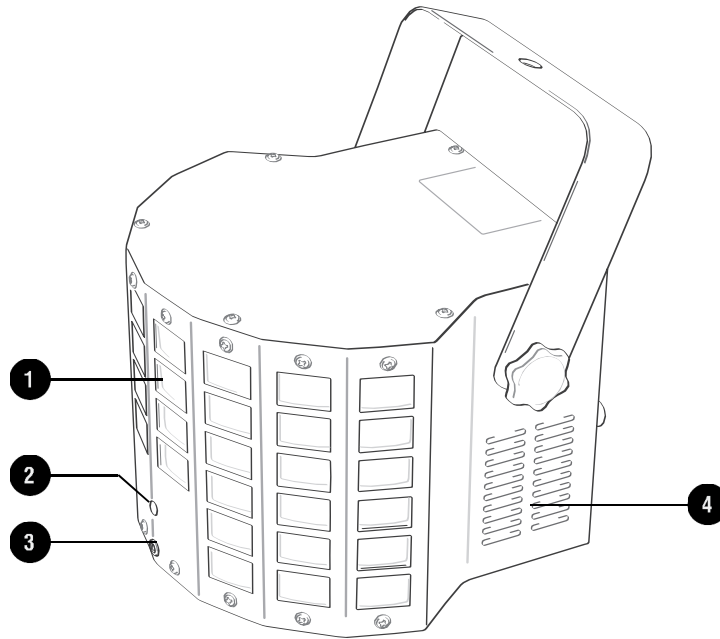

- ① Lenses
- ② 1 x RGBW LED for rotating, colored beams
- ③ Laser output aperture
- ④ Infrared receiver for the remote control
- ⑤ Fan output (do not cover to avoid overheating)

## Rear panel

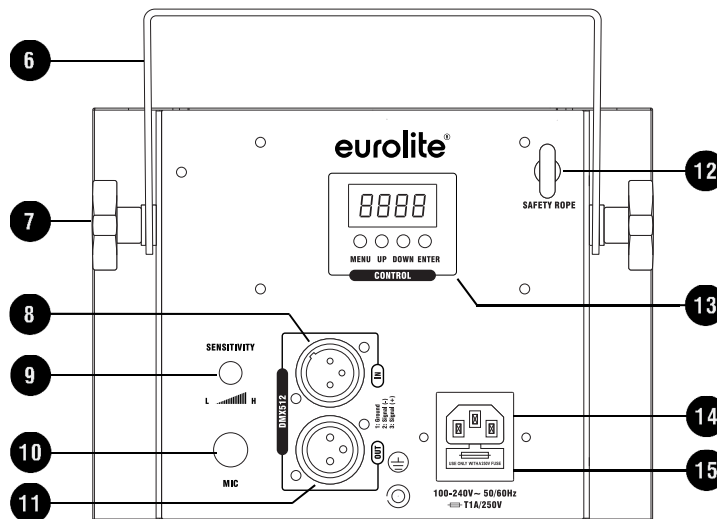

- ⑥ Mounting bracket
- ⑦ Fixation screw
- ⑧ DMX input
- ⑨ Sensitivity control for the microphone
- ⑩ Microphone
- ⑪ DMX output
- ⑫ Safety eyelet
- ⑬ Display and operating buttons
- ⑭ Power input
- ⑮ Fuse holder

# INSTALLATION

## WARNING!



### Risk of injury caused by falling objects

Devices in overhead installations may cause severe injuries when crashing down. Make sure that the device is installed securely and cannot fall down. The installation must be carried out by a specialist who is familiar with the hazards and the relevant regulations. The commissioning, operation and maintenance of this product may only be carried out by qualified personnel.

## DANGER!



### Damage caused by laser radiation

Observe the warnings on page 18 when installing the device.

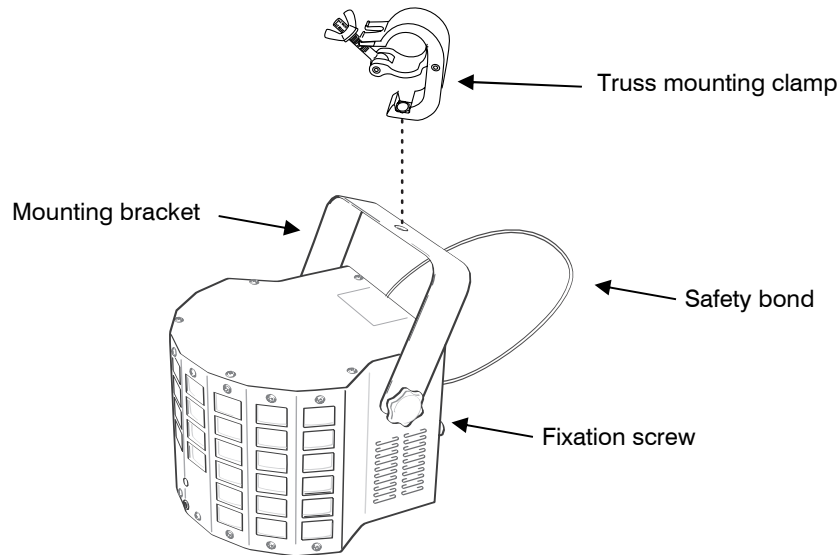

This product is designed for overhead rigging only. Mount it to a wall or ceiling with the mounting bracket. If necessary, it can also be fastened to a truss using appropriate clamps. To align the unit, release the fixation screws at the mounting bracket, adjust the desired inclination angle and retighten the fixation screws. Make sure not to point the laser beams at highly reflective surfaces such as mirror balls, windows and shiny objects. As a precaution, remove or cover up highly reflective objects in order to avoid laser reflections.

## Notes

- The device must be mounted out of normal reach.
- During installation and service work, the area below the installation location must be blocked.
- The installation of the device has to be built and constructed in a way that it can hold ten times the weight for one hour without any harming deformation.
- The device must be additionally secured with e.g. an appropriate safety bond. Pull the safety bond through the safety eyelet and fasten it in such a way that, in the event of a fall, the maximum drop distance of the device will not exceed 20 cm. This secondary safety attachment must be constructed in a way that no part of the installation can fall down if the main attachment fails.
- The safety bonds, quick links, shackles and the carabines must be sufficiently dimensioned and used correctly in accordance with the latest industrial safety regulations.
- After installation, this product requires inspections periodically to prevent the possibility of rot, deformation and looseness.



# MAKING THE CONNECTIONS

## Connection to the mains

The device uses an auto-range power supply that accepts input voltages between 100 und 240 volts.

- 1 Connect the device via the mains cable to a grounded mains socket. Thus the unit is switched on.
- 2 To switch off the unit, disconnect the power plug.
- 3 Do not connect the unit to the mains voltage via a dimmer. For a more convenient operation, connect the unit to a mains outlet which is switchable.

## DMX512 control

The unit is equipped with 3-pin XLR connectors for DMX connection.

- 1 Connect the output of your DMX controller to the DMX input DMX IN of the light set with a DMX cable.
- 2 Connect the DMX output DMX OUT of the light set to the DMX input of the next unit in the chain. Always connect one output to the input of the next unit until all units are connected.
- 3 At the last unit, the DMX cable has to be terminated. Plug the terminator with a 120  $\Omega$  resistor between Signal (-) and Signal (+) in the DMX output of the last unit.
- 4 If the cable length exceeds 300 m or the number of DMX devices is greater than 32, it is recommended to insert a DMX level amplifier to ensure proper data transmission.

XLR connection:



## MENU SETTINGS

The built-in control panel of the unit features four operating buttons and a display which shows all operation statuses. After connecting the unit to the mains it requires a short initialization process and is then ready for operation. The display indicates the last operating mode. The operating modes can be selected by means of the display and the control buttons. All settings remain stored even if the device is disconnected from the mains.

### Operating buttons

<b>MENU</b>	Selects the operating mode or returns to the initial screen.
<b>ENTER</b>	Activates a value to be modified or saves a value when modifying.
<b>UP</b>	Selects the next menu item or increases values when modifying.
<b>DOWN</b>	Selects the previous menu item or decreases values when modifying.

### Menu structure

Display		Function
Addr	A001-512	DMX start address setup
Shou	Sh 1	Show program 1: LED derby
	SP00-99	Program running speed (slow > fast)
	Sh 2	Show program 2: laser
	SP00-99	Program running speed (slow > fast)
	Sh 3	Show program 3: LED derby + Laser
	SP00-99	Program running speed (slow > fast)
	Sh 4	Show program 4: LED derby + laser with changing running speed
Soun	on	Sound control show programs 1-4
	off	Automatic mode show programs 1-4
Ver		Indication of the firmware version
TeNP		Indication of the internal temperature

## OPERATION WITHOUT EXTERNAL CONTROL

### Automatic mode

In automatic mode, 4 show programs are available of which 3 run at an adjustable speed. Make sure sound control in menu item **Soun** is disabled (**off** setting).

- 1 Press the **MENU** button so many times until **Shou** is indicated in the display. Confirm with the **ENTER** button.
- 2 Use the **UP** and **DOWN** buttons to select the desired show program. Confirm with the **ENTER** button. The display indicates menu item running speed.
- 3 Use the **UP** and **DOWN** buttons to adjust the running speed of the program from **SP00** (slow) to **SP99** (fast).

### Sound control

Via the integrated microphone the unit can perfectly reproduce the show programs to the rhythm of the music (sufficient bass provided).

- 1 Select the desired show program in menu item **Shou** as described above.
- 2 Then press the **MENU** button so many times until **Soun** is indicated in the display. Confirm with the **ENTER** button.
- 3 Activate sound control mode by selecting **on** with the **UP** and **DOWN** buttons.
- 4 Adjust the microphone sensitivity to the volume of the music with the **SENSITIVITY** control.

### Interconnecting several showlasers (master/slave operation)

Several showlasers may be interconnected (max. 32). Then all slave units can be synchronized and controlled with the master unit without the need for a DMX controller. The units must be set to the corresponding operating modes.

- 1 Configure all slave units before connecting the master unit: Press the **MENU** button so many times until **Addr** is indicated in the display. Confirm with the **ENTER** button. Use the **UP** and **DOWN** buttons to set the start address to **A001**.
- 2 Connect the DMX output of the master unit to the DMX input of the first slave unit. Then connect the DMX output of the first slave unit to the DMX input of the second slave unit, etc. until all units have been connected in a chain. Make sure the master unit is the first in the chain. Do not connect a DMX controller to the DMX input of the master unit.
- 3 Set the master unit to the desired show program. The interconnected showlasers will now operate in sync.

## REMOTE CONTROL

When actuating a button, always hold the remote control in the direction of the sensor at the unit's front. There must be visual connection between the remote control and the sensor. In DMX and slave modes, the remote control is disabled.

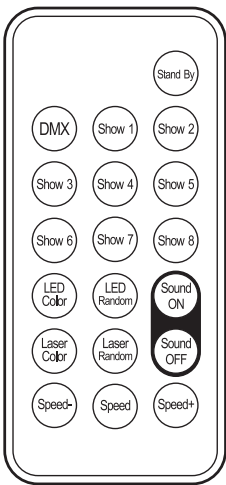

Button	Function
Stand By	LEDs and laser beams on/off
DMX	DMX mode
Show 1	Show program 1: LED derby
Show 2	Show program 2: laser
Show 3	Show program 3: LED derby + laser
Show 4	Show program 4: LED derby + laser with changing running speed
Show 5-8	no function
LED Color	Color selection for the LED beams. Change colors (15) by pressing repeatedly.
LED Random	LED beams with random colors
Laser Color	Color selection for the laser beams. Change colors (3) by pressing repeatedly.
LED Random	Laser beams with random colors
Sound ON	Enables sound control for show programs 1-4. Set the microphone SENSITIVITY on the unit (SENSITIVITY L-HI).
Sound OFF	Enables automatic mode for show programs 1-4. Set the running speed with Speed -/+.
Speed -	Running speed show program 1-3 in automatic mode down
Speed +	Running speed show program 1-3 in automatic mode up

### Notes

- The remote control is supplied with a battery inserted. An insulating foil between the battery and the battery contacts prevents the battery from being discharged during storage. Prior to the first operation remove the foil from the battery support on the rear side of the remote control. Otherwise operation of the remote control is not possible.
- If the range of the remote control decreases, replace the battery. For this purpose, on the rear side of the remote control press the small bar with the groove to the right and at the same time remove the battery support. For operation, one 3 V button cell type CR 2025 is required. When inserting, pay attention that the positive pole of the button cell shows upwards in the support.

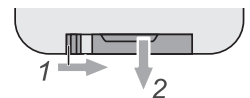

## DMX OPERATION

### Setting the number of DMX channels and the DMX starting address

For operation with a controller with DMX512 protocol, the showlaser is equipped with 13 control channels. To be able to operate the showlaser with a DMX controller, the DMX starting address must be set for the first DMX channel. The starting address depends upon which DMX controller is being used. Please refer to the controller's documentation.

- 1 Press the **MENU** button so many times until **Addr** is indicated in the display. Confirm with the **ENTER** button.
- 2 Use the **UP** and **DOWN** buttons to set the address.
- 3 A dot will light up when DMX signals are being received.

### Functions in DMX mode

Channel	DMX value			Function
1	000	-	255	Red 0-100 %
2	000	-	255	Green 0-100 %
3	000	-	255	Blue 0-100 %
4	000	-	255	White 0-100 %
5	000	-	009	no strobe effect
	010	-	255	Strobe effect (slow > fast)
6	000	-	255	Dimmer 0-100 %
7	000	-	009	Laser off
	010	-	127	Red laser on
	128	-	199	Green laser on
	200	-	255	Red and green laser on
8	000	-	009	no strobe effect
	010	-	255	Laser beams with strobe effect (slow > fast)
9	000	-	127	Index
	128	-	255	Rotation with increasing speed
10	000	-	127	Positioning 0-360°
	128	-	255	Rotation with increasing speed
11	000	-	009	No show program
	010	-	099	Show program 1: LED derby
	100	-	149	Show program 2: laser
	150	-	199	Show program 3: LED derby + laser
	200	-	255	Show program 4: LED derby + laser
12	000	-	255	Running speed show program 1-3 (slow > fast)
13	000	-	127	Automatic mode show programs 1-4
	128	-	255	Sound control show programs 1-4

## CLEANING AND MAINTENANCE

We recommend a frequent cleaning of the device. The lenses, in particular, should be clean to ensure that light will be emitted at maximum brightness. Please use a soft lint-free and moistened cloth. Never use alcohol or solvents! Before cleaning, disconnect the device from the power supply. Make sure that no liquids can enter the device.

There are no serviceable parts inside the device except for the fuse. Maintenance and service operations are only to be carried out by authorized dealers.

Should you need any spare parts, please use genuine parts. If defective, please dispose of the unusable device in accordance with the current legal regulations. Should you have further questions, please contact your dealer.

### Replacing the fuse

If the fine-wire fuse of the device fuses, only replace the fuse by a fuse of same type and rating. Before replacing the fuse, unplug mains lead.

Procedure:

- Step 1: Open the fuse holder on the rear panel with a fitting screwdriver.
- Step 2: Remove the old fuse from the fuse holder.
- Step 3: Install the new fuse in the fuse holder.
- Step 4: Replace the fuse holder in the housing.

## TECHNICAL SPECIFICATIONS

Power supply:	100-240 V AC, 50/60 Hz
Power consumption:	80 W
Fuse:	T1A/250V
Laser classification:	2M
Laser modules:	Red 100 mW, green 30 mW
Wavelength:	Red 650 nm, green 532 nm
LED:	1 x 4in1 RGBW, 30 W
DMX channels:	13
DMX512 connection:	3-pin XLR
Sound control:	via built-in microphone
Maximum ambient temperature $T_a$ :	45° C
Maximum housing temperature $T_c$ :	55° C
Battery/remote control:	CR2025 button cell 3 V
Dimensions (LxWxH):	200 x 210 x 220 mm
Weight:	2 kg

Specifications are subject to change without notice due to product improvements.

### Accessories

No. 59006856	TPC-10 Coupler, silver
No. 59006858	TPC-10 Coupler, black
No. 58010310	Safety bond A 3x600mm up to 5kg, silver
No. 58010342	Safety bond A 3x600mm up to 5kg, black



**eurolite®**

Eurolite is a brand of Steinigke Showtechnic GmbH Andreas-Bauer-Str. 5 97297 Waldbüttelbrunn Germany  
D00110324 Version 1.1 Publ. 08/02/2018

